



**Powder Coated - Headrail Braced  
STANDARD  
Metal Toilet Partitions**

## **Material Specification**

### **1 . 0 1 Construction**

---

Doors, Panels and Pilasters shall be constructed of two sheets of panel flatness zinc-coated galvanized steel, ASTM A653 GR33, laminated under pressure to a honeycomb core for sound deadening and rigidity. Formed edges to be welded together and inter-locked under tension with a roll-formed oval crown locking bar, mitred, welded and ground smooth at the corners. Honeycomb to have a maximum 25mm (1") cell size.

### **1 . 0 2 Doors**

---

Shall be 25mm (1") thick with cover sheets not less than 0.8mm (.030").

### **1 . 0 3 Panels**

---

Shall be 25mm (1") thick with cover sheets not less than 0.8mm (.030").

### **1 . 0 4 Pilasters**

---

Shall be 32mm (1.25") thick with cover sheets not less than 0.9mm (.036").

### **1 . 0 5 Headrail**

---

Shall be 25mm (1") by 41mm (1.625") extruded anodized aluminum with anti-grip design. Wall thickness to be 1.5mm (.060") and shall be securely attached to wall and pilasters with manufacturer's fittings in such a way as to make a strong and rigid installation. All joints in headrails shall be made at a pilaster.

### **1 . 0 6 Pilaster Fastening Method**

---

Pilasters shall be securely and rigidly fastened to the floor and fitted with a jack levelling screw for vertical adjustment. The floor fastening shall be concealed and protected by a 102mm (4") high, die-formed stainless steel pilaster shoe.

### **1 . 0 7 Hardware & Fittings**

---

All panel and pilaster brackets and all door hardware shall be chrome plated zinc die castings. Fasteners are zinc plated 12 x 1-3/4" and 12 x 5/8" TR-27 6-lobe security screws. Doors shall be equipped with gravity type hinges mounted on upper and lower pilaster hinge brackets. Door hinges shall be fully concealed within the thickness of the door and adjustable to permit the door to come to rest at any position when not latched. Threaded upper hinge pin shall have a metal core and self lubricating nylon sleeve to ensure smooth, quiet operation. Each door to be fitted with a combined coat hook and bumper and a concealed latch, with face mortised flush with edge strip of door. The combined stop and keeper shall have a 19mm (0.75") diameter bumper locked in place.

### **1 . 0 8 Finish**

---

All sheet metal to be thoroughly cleaned, phosphated and finished with a high performance powder coating, baked on to provide a uniform smooth protective finish.

Color shall be as selected from options provided by ToiletPartitions.com.



**Stainless Steel - Headrail Braced**  
**STANDARD**  
**Metal Toilet Partitions**

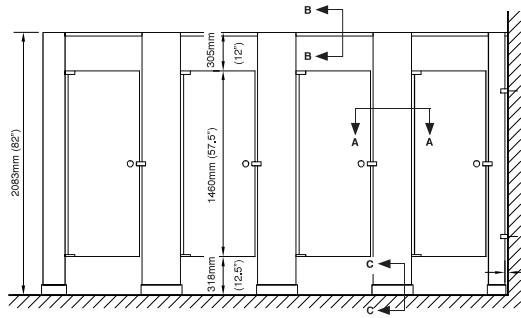

front elevation

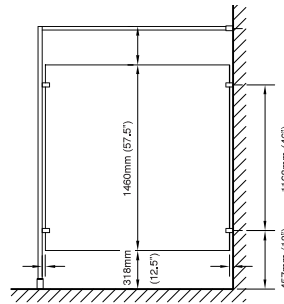

side elevation

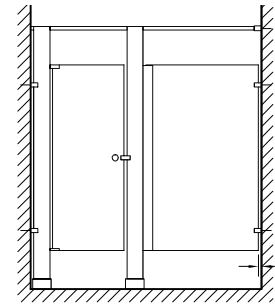

alcove elevation

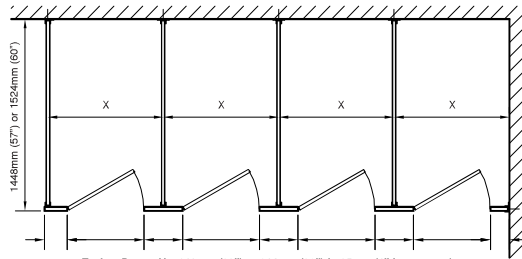

plan

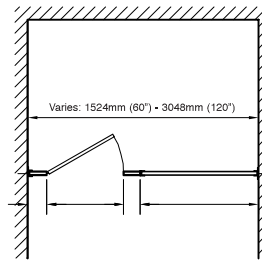

alcove plan

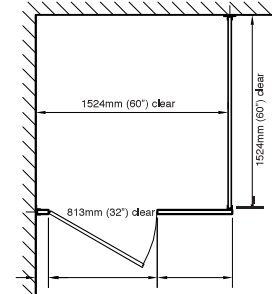

barrier-free plan

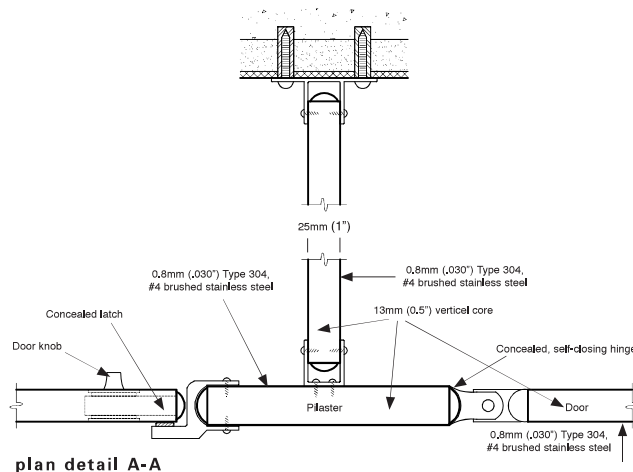

plan detail A-A

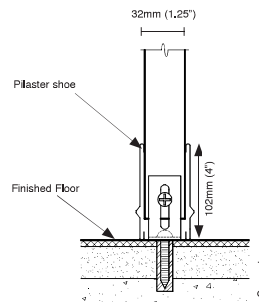

section detail C-C

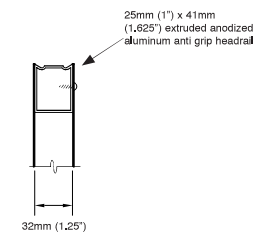

section B-B

**Important Note:**

Refer to final drawings for wood blocking information. Wood blocking is critical to ensure a rigid installation.